

Water Flow Indicator with Retard (ZSJZYS)

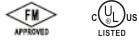

ZSJZYS



- Connection Ends: AWWA C606
- Working Pressure: 363PSI and 300PSI
200PSI and 250PSI available upon request
- Temperature Range: 0°C - 68°C
- Coating: Fusion Bonded Epoxy Coating in accordance with ANSI/AWWA C550
- Electrical Ratings: 125/250VAC 5A 24/30VDC 3A
- Minimum Flow Rate For Alarm: 4-10 gpm

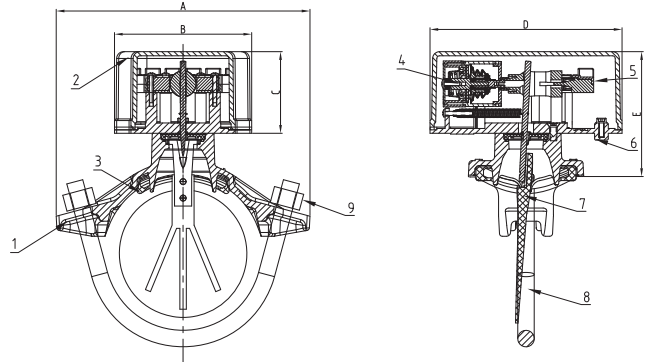

MATERIAL SPECIFICATION

Part No.	Part	Standard Specification	Options
1	Body	ASTM A536,65-45-12	
2	Cover	Aluminum Alloy	
3	Gasket	EPDM	NBR
4	Delay Device	Plastic	
5	Signal Connection	N/A	
6	Connection Plate	Aluminum Alloy	
7	Vane	Plastic	
8	U-Bolts	Carbon Steel Zinc Plated	AISI 304, AISI 316
9	Nuts	Carbon Steel Zinc Plated	AISI 304, AISI 316

Note: For special material request other than standard specification, please indicate clearly on the inquiry or order list.

WIRING DIAGRAM

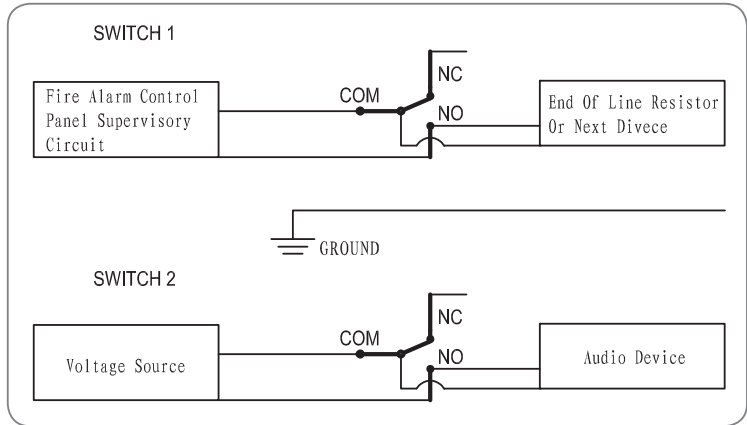

DN		Dimensions(mm)						
Inch	mm	R	A	B	C	D	E	Hole Dia.
2"	50	60.3	116	100	59.5	140	79.5	29
2.5"	65	73	120	100	59.5	140	79.5	29
2.5"	65	76.1	120	100	59.5	140	79.5	29
3"	80	88.9	145	100	59.5	140	80.9	51
4"	100	114.3	185	100	59.5	140	98.5	51
5"	125	139.7	212	100	59.5	140	82.6	51
5"	125	141.3	212	100	59.5	140	82.6	51
6"	150	165.1	254	100	59.5	140	90.4	51
6"	150	168.3	254	100	59.5	140	90.4	51
8"	200	219.1	298	100	59.5	140	90.5	51
10"	250	273.0	381	100	59.5	140	100.5	70

Note: Size 10" is not UL listed.