

Flanged Y-Type Strainer (V4), UL Listed

0E3072.7



V4



NSF/ANSI 61 NSF/ANSI 372

- Connection Ends: Flange to ASME B16.1 Class 125 / ASME B16.42 Class 150
- Working Pressure: 300PSI
200PSI and 250PSI available upon request
- Temperature Range: -10°C- 200°C Graphite Gasket
0°C- 100°C Rubber Gasket
- Coating: Fusion Bonded Epoxy Coating in accordance with ANSI/AWWA C550

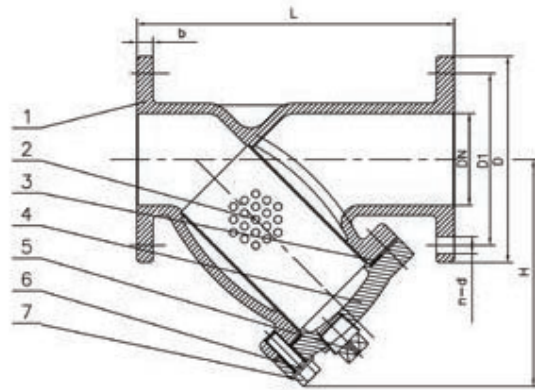

MATERIAL SPECIFICATION

Part No.	Part	Standard Specification	Options
1	Valve Body	ASTM A536 65-45-12	
2	Screen	AISI 304 (Perforated)	AISI 304, AISI 316 (Perforated, Knitted, Double Screen)
3	Gasket	Graphite + Acanthopore Plate	EPDM
4	Bonnet	ASTM A536 65-45-12	
5	Plug	Malleable Iron Galvanized	Bronze ASTM B584
6	Bolt	Carbon Steel Zinc Plated	AISI 304, AISI 316
7	Flat Washer	Carbon Steel Zinc Plated	AISI 304, AISI 316

Note: For special material request other than standard specification, please indicate clearly on the inquiry or order list.

DN		Dimensions(mm)					
Inch	mm	L	D	D1	b	n-Φd	H
2"	50	200	152	120.5	16	4-Φ19.1	155
2.5"	65	254	178	139.5	17.5	4-Φ19.1	165
3"	80	257	191	152.5	19	4-Φ19.1	180
4"	100	308	229	190.5	24	8-Φ19.1	229
5"	125	397	254	216	24	8-Φ22.2	285
6"	150	470	279	241.5	25.5	8-Φ22.2	311
8"	200	549	343	298.5	28.5	8-Φ22.2	394
10"	250	654	406	362	30.5	12-Φ25.4	487
12"	300	759	483	432	32	12-Φ25.4	547