



VÁLVULAS DE ESFERA PASO TOTAL IDEAL

093 Válvula de esfera Ideal, paso total

Indicadas para el uso en instalaciones hidráulicas, de calefacción, de acondicionamiento y neumáticas.

IDEAL



MEDIDA	PRESIÓN	CÓDIGO	EMBALAJE
1/4" (DN 8)	50bar/725psi	0930014/N	15/165
3/8" (DN 10)	50bar/725psi	0930038/N	15/165
1/2" (DN 15)	50bar/725psi	0930012/N	12/96
3/4" (DN 20)	40bar/580psi	0930034/N	8/64
1" (DN 25)	40bar/580psi	0930100/N	8/64
1"1/4 (DN 32)	30bar/435psi	0930114/N	4/32

CERTIFICACIONES



ESPECIFICACIONES

Conexiones roscadas hembra/hembra o macho/hembra.

Mando palanca en acero (aluminio en las medidas 2"1/2 - 3" - 4") o mando mariposa en aluminio o mando palanca plana en acero recubierta.

Cuerpo de latón niquelado.

Temperatura mínima y máxima de trabajo: -20°C, 150°C en ausencia de vapor.

Attacchi filettati ISO 228 (equivalente a DIN EN ISO 228 e BS EN ISO 228).

Indique "N" solo para la adquisición de la válvula con manilla negra.



VÁLVULAS DE ESFERA PASO TOTAL IDEAL

Dimensiones totales

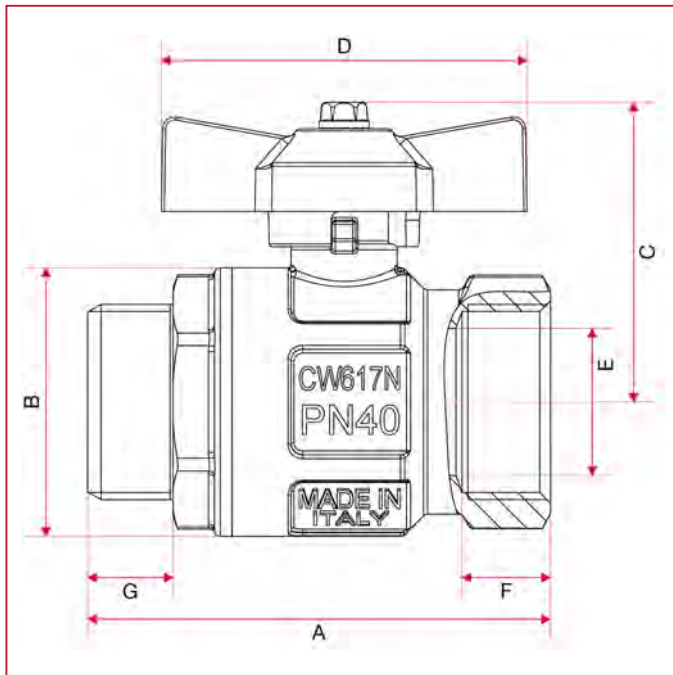

	1/4"	3/8"	1/2"	3/4"	1"	1"1/4
DN	8	10	15	20	25	32
A	54	54	58,5	66,5	78,5	91,5
B	23,5	24	30,5	37	45,5	57
C	37	37	41	47	51	64
D	47	47	47	62	62	70
E	8	10	15	20	25	32
F	10	10	12	12,5	15	17
G	10,5	10,5	11,5	13,5	14,5	17
Kg/cm2 bar	50	50	50	40	40	30
LBS - psi	725	725	725	580	580	435



VÁLVULAS DE ESFERA PASO TOTAL IDEAL

MATERIALES

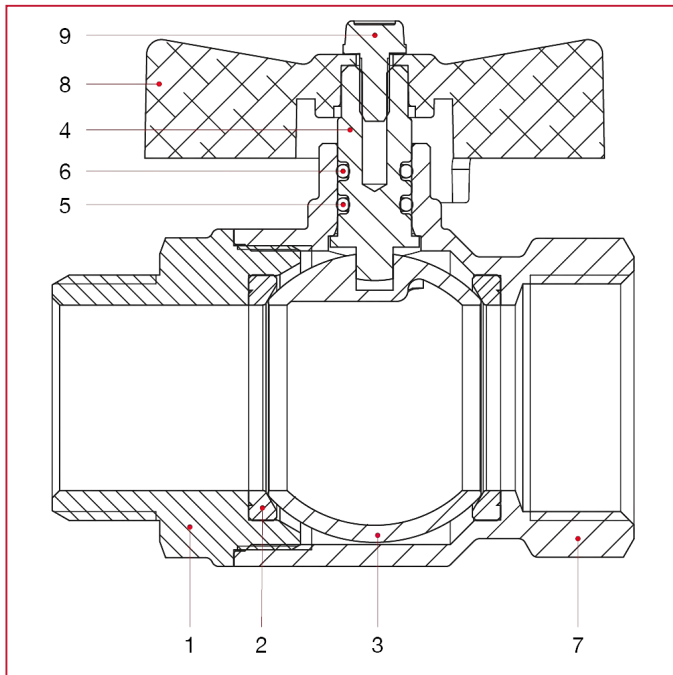

POS.	DESCRIPCIÓN	N.	MATERIAL
1	Male end adapter	1	Nickel-plated brass CW617N
2	Seat	2	P.T.F.E.
3	Ball	1	Chrome-plated brass CW617N
4	Stem	1	Brass CW614N
5	O-ring	1	NBR
6	O-ring	1	Viton®
7	Body	1	Nickel-plated brass CW617N
8	T handle	1	Varnished aluminium
9	Screw	1	Zinc-plated steel C4C



VÁLVULAS DE ESFERA PASO TOTAL IDEAL

INSTALACIÓN

The itap S.p.A.'s valves are bi-directional, that means they manage the flow in both the directions.

The valves are composed by a ball, two seal in PTFE material, one stem, two sailing rings (O-Rings), one handle and a couple of parts made of brass (body and end adapter) that contain them and that are assembled by means of thread and a sealed material to obtain their aim.

In order to avoid that the sealed material gets broken and then the valve loses the connection between the body and the end-adapter, it's necessary to avoid to submit the two parts under the influence of a torque.

For the installation normal hydraulic practices must be used, and especially:

- ones have to be sure that the two pipes are correctly aligned;
- during the assembling process the installer has to apply its assembling tools at the end that is nearest to the pipe;
- the application of the sealing materials by the fitter (PTFE or hempen cloth) must be limited at the thread zone. An excess should interfere in the ball-gasket's closure zone, compromising the tightness.
- in the case that the fluid transported presents some impurities (dust, water too hard, etc.) ones have to remove these impurities by the means of a filter. Otherwise they could damage the seals.

DESINSTALAR

To remove the valve from the pipe line or anyhow before to unscrew the junctions linked to it:

- wear the clothing protective normally required to work with the fluid transported within the line;
- depressurize the line and operate in this way:
 - positioning the valve in opened position and then empty the line;
 - handle the valve to put down the residue pressure contained inside the space between the ball and the body before of remove it from the line;
 - during the disassembly apply the screw tool at the end of the valve nearest the pipe;

MANTENIMIENTO

Verify the valve periodically, according to its application's field and its works' field and its work's conditions, in order to be sure that the valve works correctly.

FABRICANTE

ITAP S.p.A.

Via Ruca 19/21 - 25065

Lumezzane (BS), Italy

Teléfono: +39 030 8927011

Fax: +39 030 8921990

email: info@itap.it

web: www.itap.it



VÁLVULAS DE ESFERA PASO TOTAL IDEAL

DIAGRAMA DE PÉRDIDAS DE CARGA (con agua)

	1/4"	3/8"	1/2"	3/4"	1"	1"1/4"
KV	3,45	5,00	15,65	26,26	41,44	63,69

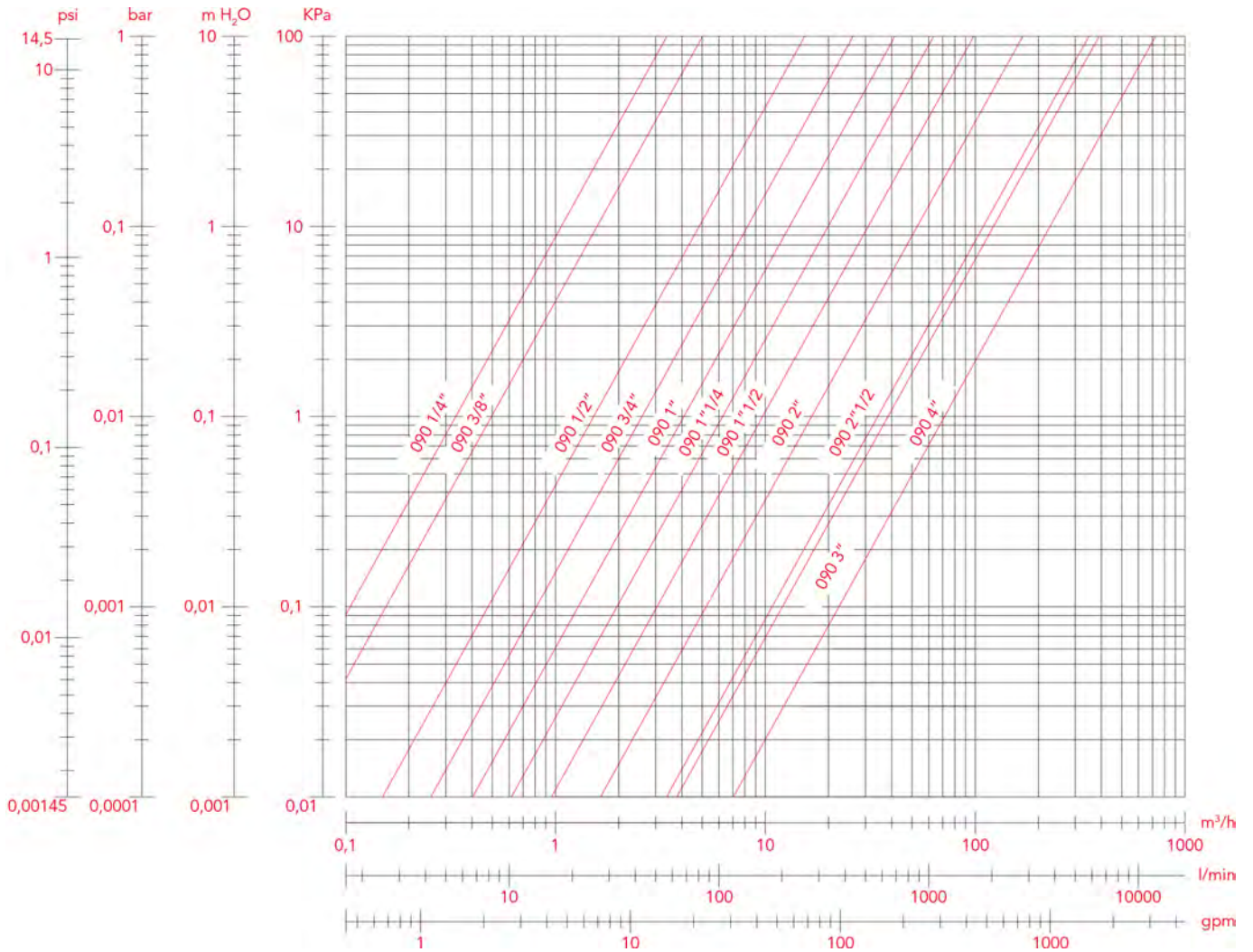



VÁLVULAS DE ESFERA PASO TOTAL IDEAL

DIAGRAMA DE PRESIÓN-TEMPERATURA

The values shown by the dropping lines state the maximum limit of employment of the valves.
The shown values are approximate.

